

**Match Radiale Iseo.**  
**Un incontro reversibile,**  
**elettrizzante...**

**Match Radiale Iseo.**  
**An electrifying**  
**reversible striker.**

**I**SEO

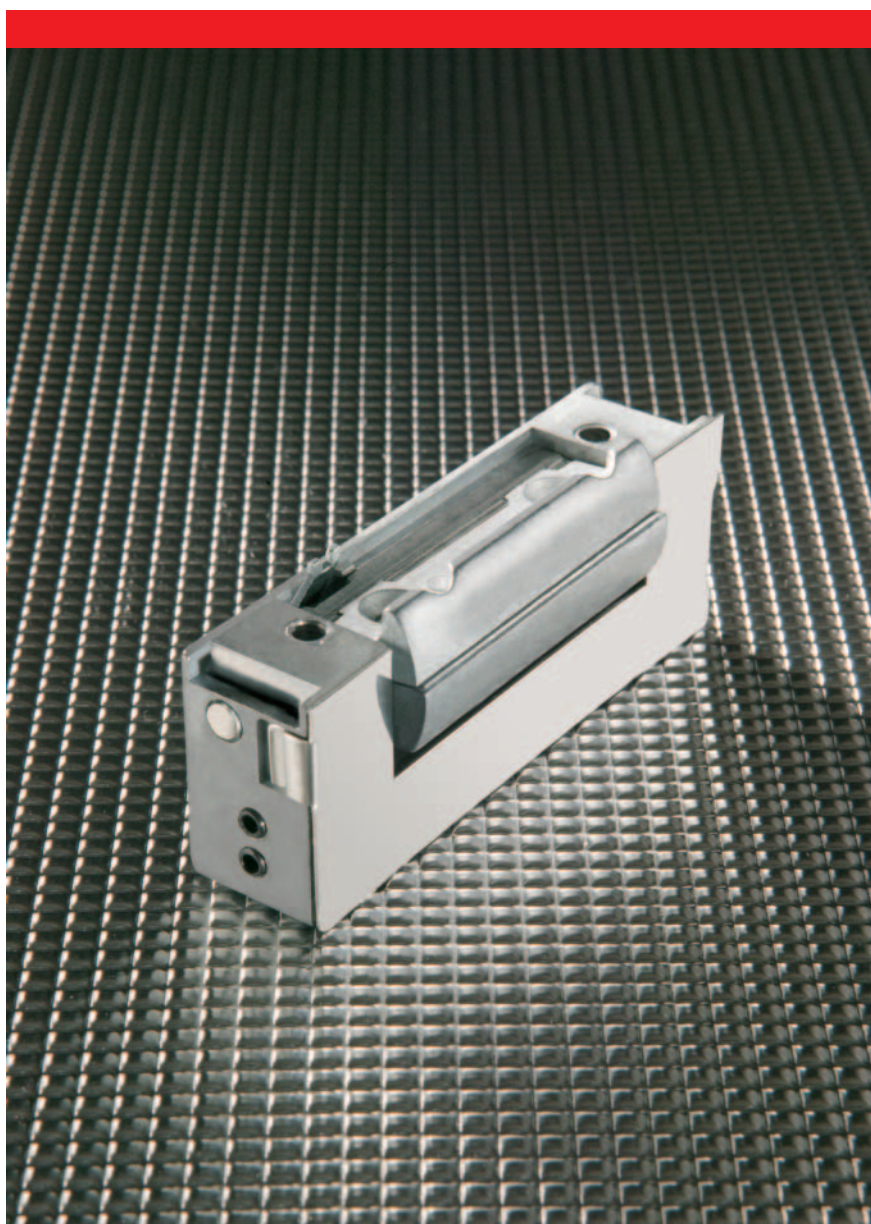

**Match Radiale Iseo.  
Riassunto  
delle qualità:**

**Reversibilità.**

**Radialità  
a scomparsa.**

**Regolazione fino  
a 3 mm.**

**Versatilità.**

**Gamma.**

**Resistenza  
allo sfondamento.**

**Iseo Match Radiale.  
Qualities  
summary:**

**Reversibility.**

**Radiality.**

**Adjustment  
up to 3 mm.**

**Versatility.**

**Range.**

**Breaking resistance.**

## **Match Radiale Iseo. Un incontro reversibile, elettrizzante...**

### **Per la reversibilità.**

Una soluzione unica: versione destra o versione sinistra, non importa.

### **Per la radialità a scomparsa.**

La bassa sporgenza dell'elemento mobile (scivolo) rispetto alla versione tradizionale, non costringe ad una lavorazione di scasso superiore alla dimensione del frutto.

### **Per la regolazione fino a 3 mm.**

Una volta installato, è possibile una regolazione della parte mobile fino a 3 mm.

### **Per la versatilità.**

I 17,6 mm della cassa lo rendono adatto a tutti i supporti: alluminio, ferro, legno, PVC.

### **Per la gamma.**

Funzione di sganciamento permanente o limitato, senza perni a vista, per eliminare tutti i problemi legati alla regolazione tra serrature ed incontro elettrico.

Alimentazione a 6, 12, 24 V, AC/CD. Versione senza bobina con leva fermo a giorno, e versione ad interruzione di corrente.

### **Per la resistenza allo sfondamento.**

Maggiore di 350 kg.  
Testato oltre 200.000 cicli.

## **Iseo Match Radiale. An electrifying reversible striker.**

### **For reversibility.**

A single solution: right or left version, it makes no difference.

### **For radiality.**

The low projection of the mobile element (slide) with respect to the traditional version, does not require a breakage area on the frame door larger than the dimension of the product.

### **For adjustment up to 3 mm.**

Once installed, the moveable section can be adjusted up to 3 mm.

### **For versatility.**

The 17.6 mm case is adaptable to all supports:  
Aluminum, iron, wood, PVC.

### **For the range.**

Standard or automatic, unlocking function, both without exposed pins, to eliminate all regulation problems between locks and electric strikers.

6V, 12V or 24 V power supply, AC/DC. Version without solenoid with dogging device lever, and fail safe version.

### **For high break resistance.**

Greater than 350 Kg.  
Tested for more than 200,000 cycles.

**ISEO**

**Adatto  
per serrature  
Iseo serie:  
78  
96\*7  
96\*9  
98**

**Suitable  
for Iseo locks  
type:  
78  
96\*7  
96\*9  
98**

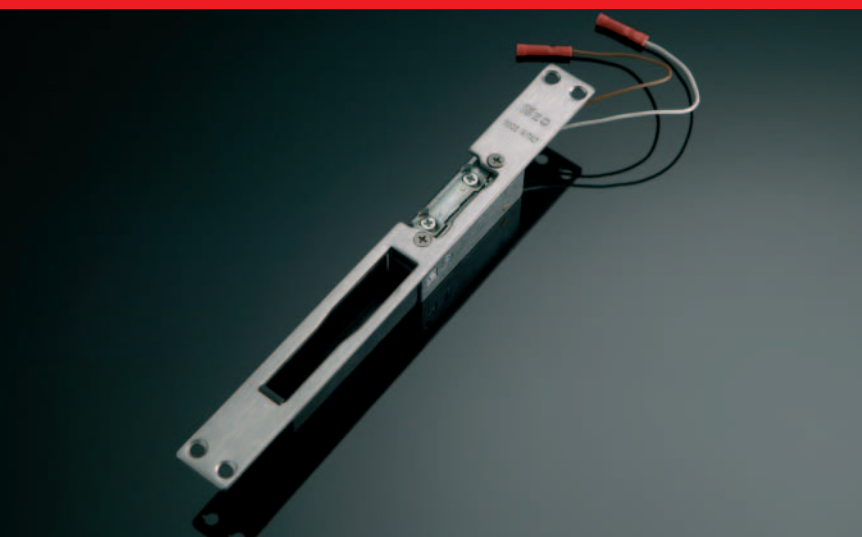

**Con vaschetta  
With cap**

<b>Codice Code</b>	<b>Voltaggio Voltage</b>	<b>Assorbimento Absorption</b>	<b>Imballo Packing</b>
<b>5661900</b>	<b>6-12 V. AC/DC°</b>	<b>Da 0.5 a 1.5 A From 0.5 to 1.5 A</b>	<b>1</b>

**CE**

° Tempo massimo  
di alimentazione:  
10 secondi  
Maximum power  
supply time:  
10 seconds

**Incontro elettrico  
con frontale piatto  
lungo in acciaio inox  
satinato con vaschetta  
catenaccio.**

**Electric striker with  
long forend plate in  
satin-finished  
stainless steel with  
dead-bolt cap.**

Versione a sganciamento  
permanente con leva fermo a  
giorno. L'incontro rimane sganciato  
dopo l'impulso elettrico.

La chiusura avviene solo dopo  
l'apertura e la richiusura della  
porta. Versione adatta per  
serrature a montante.

**Reversible.**

Automatic unlatching version with  
dogging device lever.

The striker remains unlatched after  
the electric impulse.

Locking occurs only after the  
opening and reclosing of the door.

Version adapted for mortice locks  
for aluminium frames.

**Reversible.**

**ISEO**

Cavi alimentazione  
lunghezza  
minima = 150 mm  
con connettori d.4x25

Supply cables:  
minimum  
length = 150 mm  
with 4x25 connector

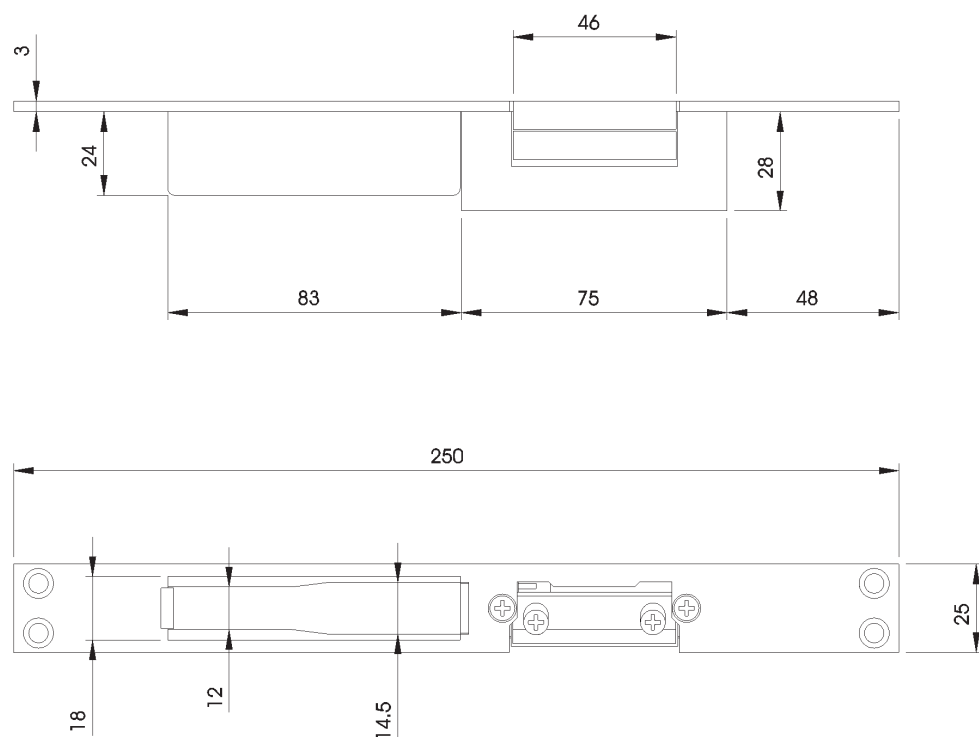



<b>Codice Code</b>	<b>Voltaggio Voltage</b>	<b>Assorbimento Absorption</b>	<b>Imballo Packing</b>
<b>040030</b>	<b>6-12 V. AC/DC°</b>	<b>Da 0.5 a 1.5 A From 0.5 to 1.5 A</b>	<b>6</b>
<b>040070</b>	<b>24 V. AC/DC°</b>	<b>0.5 A</b>	<b>6</b>

CE

° Tempo massimo  
di alimentazione:  
10 secondi  
Maximum power  
supply time:  
10 seconds

**Incontro elettrico senza frontale.  
Versione a sganciamento permanente con leva fermo a giorno.**

L'incontro rimane sganciato dopo l'impulso elettrico. La chiusura avviene solo dopo l'apertura e la richiusura della porta.

**Electrical striker without forend plate.  
Automatic unlatching version with dogging device lever.**

The striker remains unlatched after the electric impulse. Locking occurs only after the opening and reclosing of the door.



Cavi alimentazione  
lunghezza  
minima = 150 mm  
con connettori d.4x25

Supply cables:  
minimum  
length = 150 mm  
with 4x25 connector

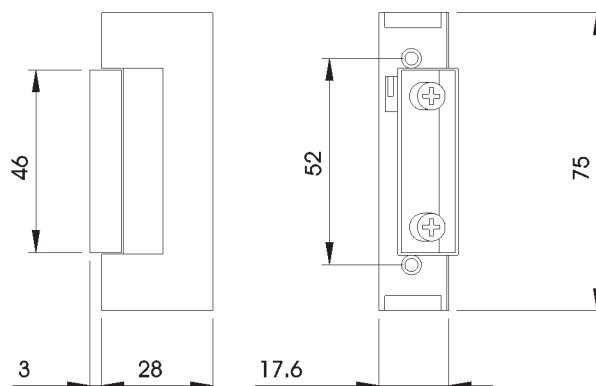
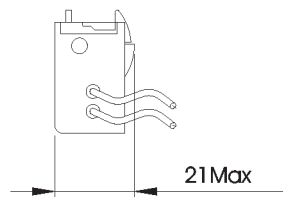



<b>Codice Code</b>	<b>Voltaggio Voltage</b>	<b>Assorbimento Absorption</b>	<b>Imballo Packing</b>
<b>040040</b>	<b>6-12 V. AC/DC°</b>	<b>Da 0.5 a 1.5 A From 0.5 to 1.5 A</b>	<b>6</b>
<b>040080</b>	<b>24 V. AC/DC°</b>	<b>0.5 A</b>	<b>6</b>

CE

° Tempo massimo  
di alimentazione:  
10 secondi  
Maximum power  
supply time:  
10 seconds



**Incontro elettrico senza frontale. Versione a sganciamento permanente senza leva fermo a giorno.**

**Electrical striker without forend plate. Automatic unlatching version without dogging device lever.**

L'incontro rimane sganciato dopo l'impulso elettrico.

The striker remains unlatched after the electric impulse.

La chiusura avviene solo dopo l'apertura e la richiusura della porta.

Locking occurs only after the opening and reclosing of the door.



Cavi alimentazione  
lunghezza  
minima = 150 mm  
con connettori d.4x25

Supply cables:  
minimum  
length = 150 mm  
with 4x25 connector

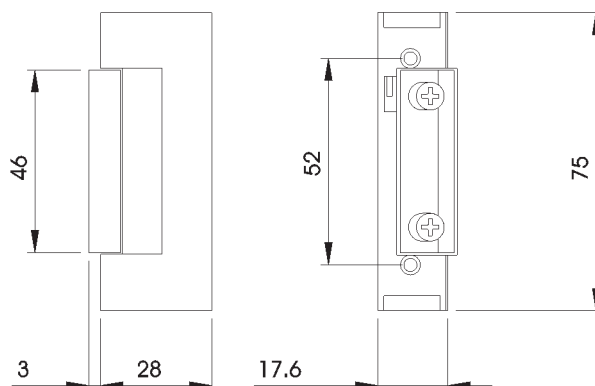
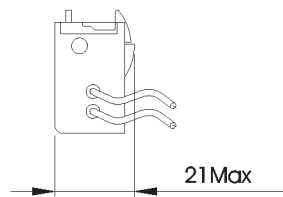



Codice Code	Voltaggio Voltage	Assorbimento Absorption	Imballo Packing
040010	6-12 V. AC/DC°	Da 0.5 a 1.5 A From 0.5 to 1.5 A	6
040050	24 V. AC/DC°	0.5 A	6

CE

° Tempo massimo  
di alimentazione:  
10 secondi  
Maximum power  
supply time:  
10 seconds

**Incontro elettrico senza frontale. Versione a sganciamento limitato con leva fermo a giorno.**

**Electrical striker without forend plate. Standard unlatching version with dogging device lever.**

L'incontro rimane sganciato solo durante l'impulso elettrico.

The striker remains unlatched only during the electric impulse.

La chiusura si ripristina automaticamente al termine dell'impulso elettrico.

Locking is done automatically after the electric impulse.



Cavi alimentazione  
lunghezza  
minima = 150 mm  
con connettori d.4x25

Supply cables:  
minimum  
length = 150 mm  
with 4x25 connector

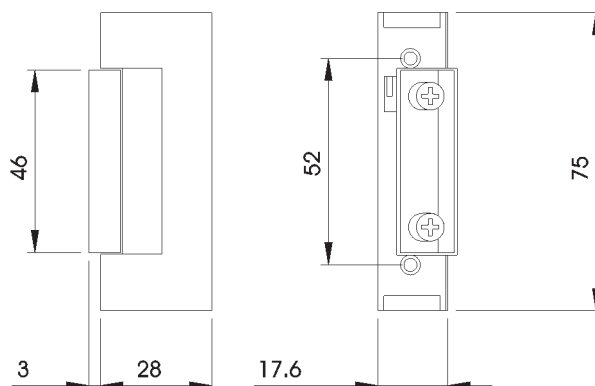
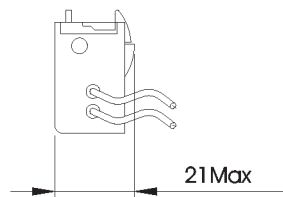



Codice Code	Voltaggio Voltage	Assorbimento Absorption	Imballo Packing
040020	6-12 V. AC/DC°	Da 0.5 a 1.5 A From 0.5 to 1.5 A	6
040060	24 V. AC/DC°	0.5 A	6

CE

° Tempo massimo  
di alimentazione:  
10 secondi  
Maximum power  
supply time:  
10 seconds

**Incontro elettrico senza frontale. Versione a sganciamento limitato senza leva fermo a giorno.**

**Electrical striker without forend plate. Standard unlatching version without dogging device lever.**

L'incontro rimane sganciato solo durante l'impulso elettrico.

The striker remains unlatched only during the electric impulse.

La chiusura si ripristina automaticamente al termine dell'impulso elettrico.

Locking is done automatically after the electric impulse.



Cavi alimentazione  
lunghezza  
minima = 150 mm  
con connettori d.4x25

Supply cables:  
minimum  
length = 150 mm  
with 4x25 connector

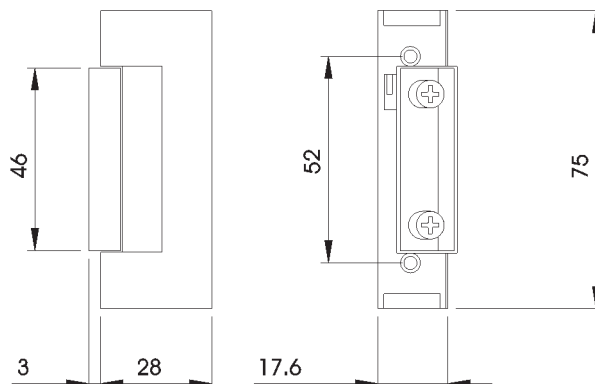
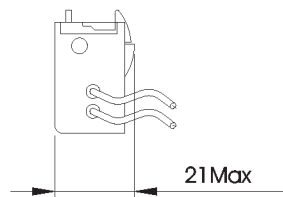



Codice Code	Imballo Packing
040090	6

CE

**Incontro elettrico senza frontale.  
Versione senza bobina con fermo a giorno.**

**Electrical striker without forend plate.  
Version without solenoid with dogging device.**

L'incontro ha funzione solo meccanica data dalla leva di fermo a giorno. Lo sganciamento non può essere effettuato elettricamente.

The striker only has mechanical operation coming from the dogging device lever. Unlocking cannot be done electrically.

**ISEO**

Cavi alimentazione  
lunghezza  
minima = 150 mm  
con connettori d.4x25

Supply cables:  
minimum  
length = 150 mm  
with 4x25 connector

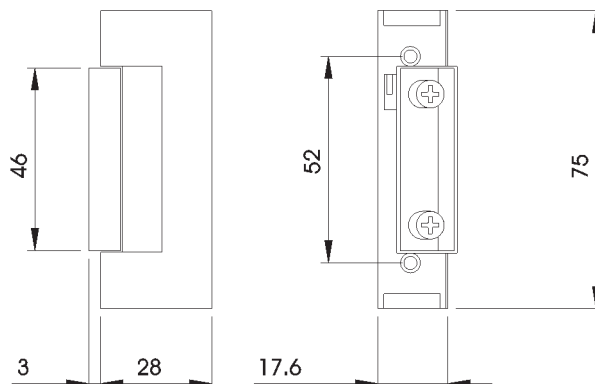
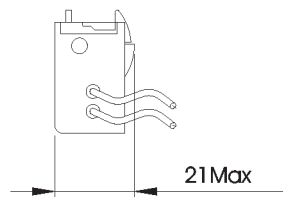



<b>Codice Code</b>	<b>Voltaggio Voltage</b>	<b>Assorbimento Absorption</b>	<b>Imballo Packing</b>
<b>040100</b>	<b>12 V. DC</b>	<b>0.3 A</b>	<b>6</b>
<b>040110</b>	<b>24 V. DC</b>	<b>0.2 A</b>	<b>6</b>

CE



**Incontro elettrico  
senza frontale. Versione a  
interruzione di corrente  
senza leva fermo a giorno.**

**Electrical striker without  
forend plate. Fail safe  
version without dogging  
device lever.**

La chiusura avviene quando  
l'incontro è sotto tensione.  
Funzione **Fail Safe** (l'apertura  
avviene solo in caso di interruzione  
di corrente).

Locking occurs when the striker  
has power. **Fail Safe** function  
(opening occurs only when there is  
power failure).

**ISEO**

Cavi alimentazione  
lunghezza  
minima = 150 mm  
con connettori d.4x25

Supply cables:  
minimum  
length = 150 mm  
with 4x25 connector

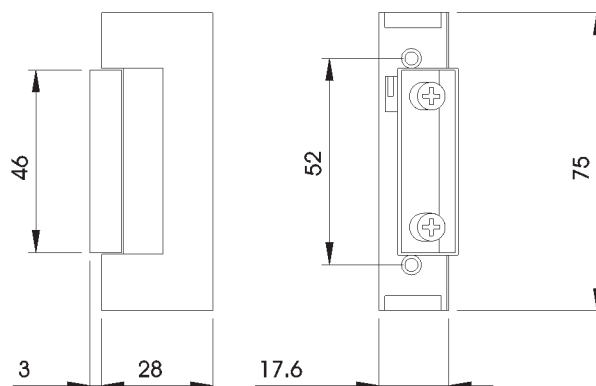
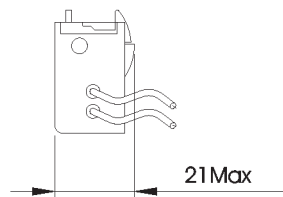

**Adatto  
per serrature  
Iseo serie:**  
78  
96\*7  
96\*9  
98

**Suitable  
for Iseo locks  
type:**  
78  
96\*7  
96\*9  
98



**Con vaschetta  
With cap**

Codice Code	Imballo Packing
----------------	--------------------

033190	10
--------	----



**Con tappi  
e vaschetta**

**With plugs  
and cap**

Codice Code		Imballo Packing
----------------	--	--------------------

033194	DX RH	10
--------	----------	----

033195	SX LT	10
--------	----------	----

**Frontale piatto lungo in acciaio inox satinato con vaschetta catenaccio.**

**Long forend plate in satin-finished stainless steel with dead-bolt cap.**

**Versione adatta per serrature a montante. Reversibile.**

**Version adapted for mortice locks for aluminium frames. Reversible.**

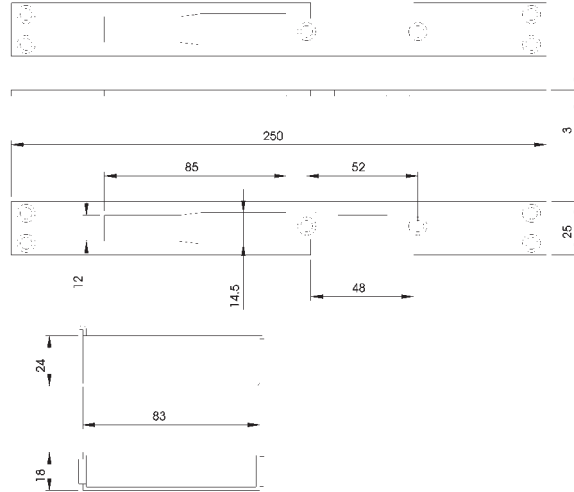

**Frontale lungo a "u" in acciaio inox satinato con tappi e vaschetta catenaccio.**

**Long u-shaped forend plate made of satin-finished stainless steel with plugs and dead-bolt cap.**

**Versione adatta per serrature a montante.**

**Version adapted for mortice locks for aluminium frames.**

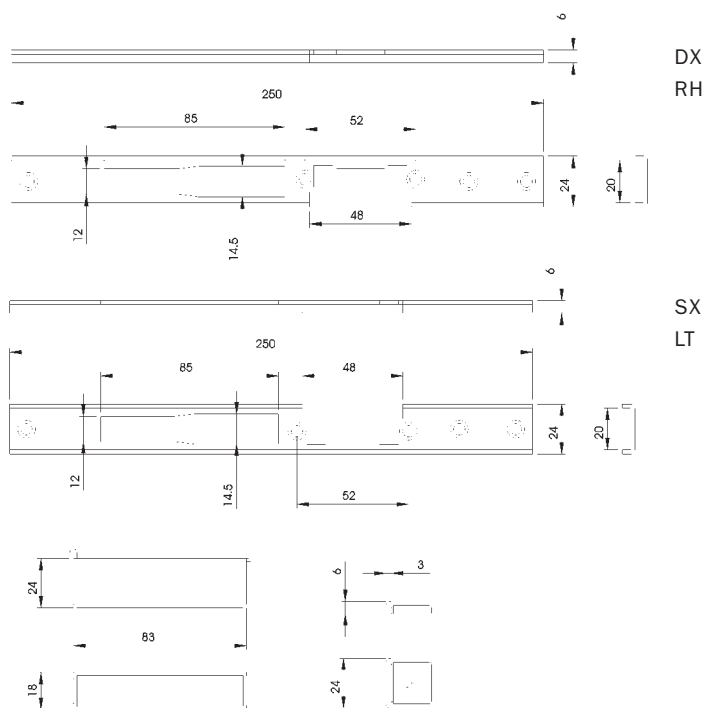

**Adatto  
per serrature  
Iseo serie:  
200-205-210  
215-221-240  
250-741-291**

**Suitable  
for Iseo locks  
type:  
200-205-210  
215-221-240  
250-741-291**



**Con vaschetta  
With cap**

Codice Code	Imballo Packing
033193	10



**Con vaschetta  
With cap**

Codice Code		Imballo Packing
033191	DX RH	10
033192	SX LT	10

**Frontale piatto lungo  
in acciaio inox satinato  
con vaschetta catenaccio.**

**Long forend plate in  
satin-finished stainless  
steel with dead-bolt cap.**

Versione adatta per serrature per  
serramenti in legno.

Version adapted for mortice  
locks for wooden frames.

**Reversible.**

**Reversible.**

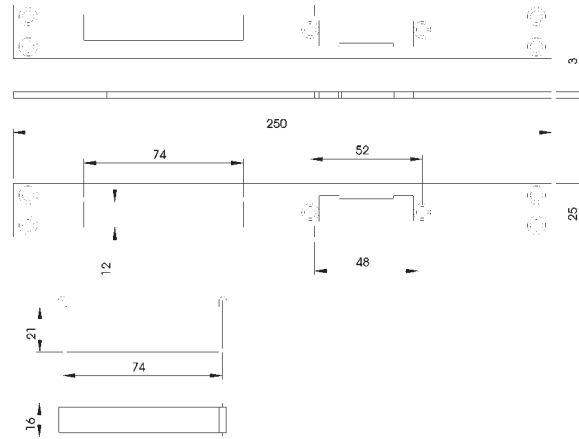

**Frontale angolare  
lungo in acciaio verniciato  
marrone.**

**Long angular forend plate  
in brown painted steel.**

Versione adatta per serrature da  
infilare per serramenti in legno.

Version adapted for mortice locks  
for wooden frames.

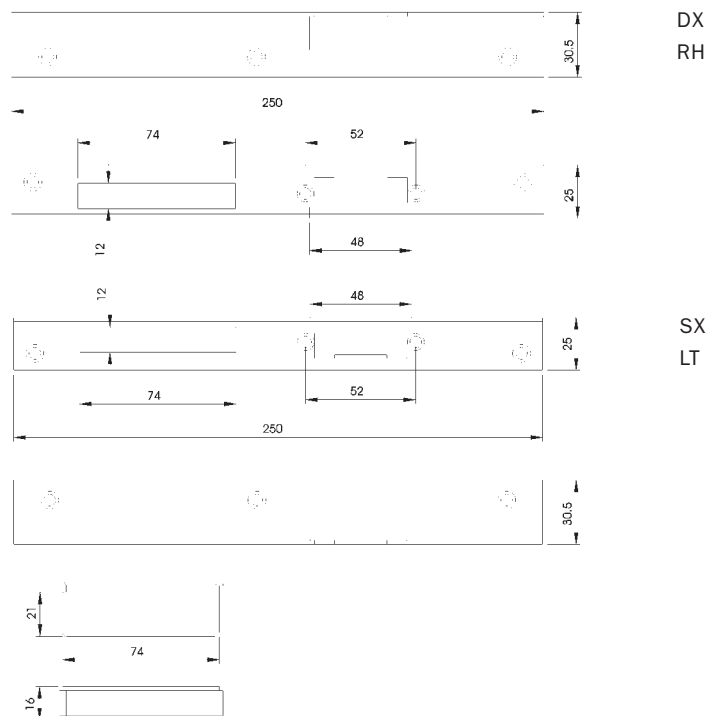



Codice Code	Imballo Packing
-------------	-----------------

033196	10
--------	----



Codice Code	Imballo Packing
-------------	-----------------

033197	10
--------	----

Con tappi  
With plugs

**Frontale piatto corto in acciaio inox satinato.**

**Short forend plate made of satin-finished stainless steel.**

**Reversibile.**

**Reversibile.**



**ISEO**

**Frontale a "u" corto in acciaio inox satinato con tappi.**

**Short u-shaped forend plate made of satin-finished stainless steel with plugs.**

**Reversibile.**

**Reversibile.**

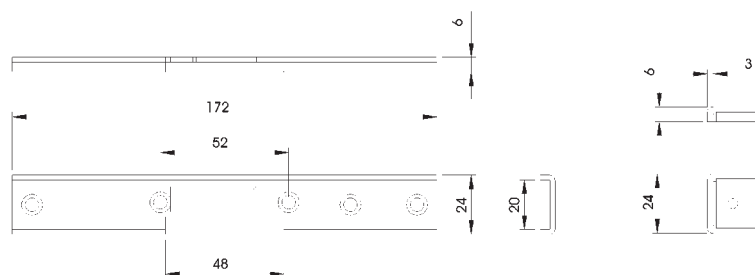

Adatto  
per serrature  
Iseo serie:  
79\*

Suitable  
for Iseo locks  
type:  
79\*



Con vaschetta  
With cap

Codice Code		Imballo Packing
033160	DX RH	10
033161	SX LT	10



Con tappi  
e vaschetta  
With plugs  
and cap

Codice Code		Imballo Packing
033162	DX RH	10
033163	SX LT	10



**Frontale piatto regolabile  
per serrature Multiblindo.**

**Adjustable forend plate for  
Multiblindo locks.**

**Frontale centrale 24x3x220 mm in  
acciaio inox.**

**Stainless steel forend plate for  
central lock 24x3x220 mm.**

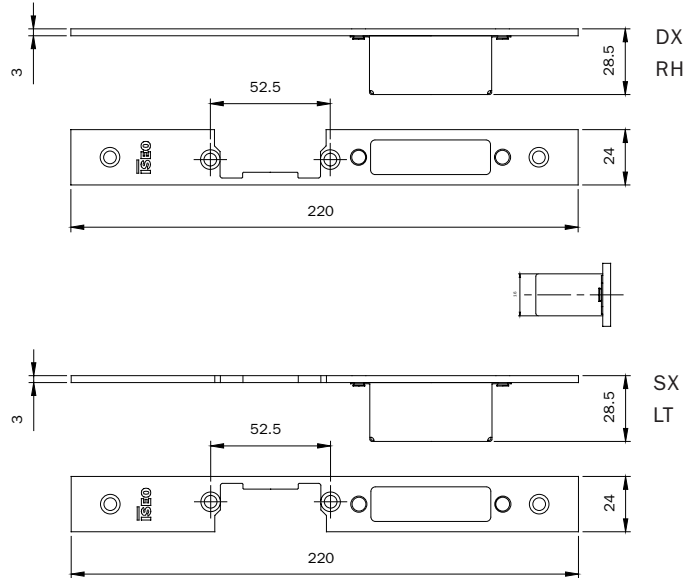

**ISEO**

**Frontale a "u" regolabile  
per serrature Multiblindo.**

**Multiblindo U-shaped  
forend plate for  
Multiblindo locks.**

**Frontale centrale 24x6x220 mm in  
acciaio inox.**

**Stainless steel forend plate for  
central lock 24x6x220 mm.**

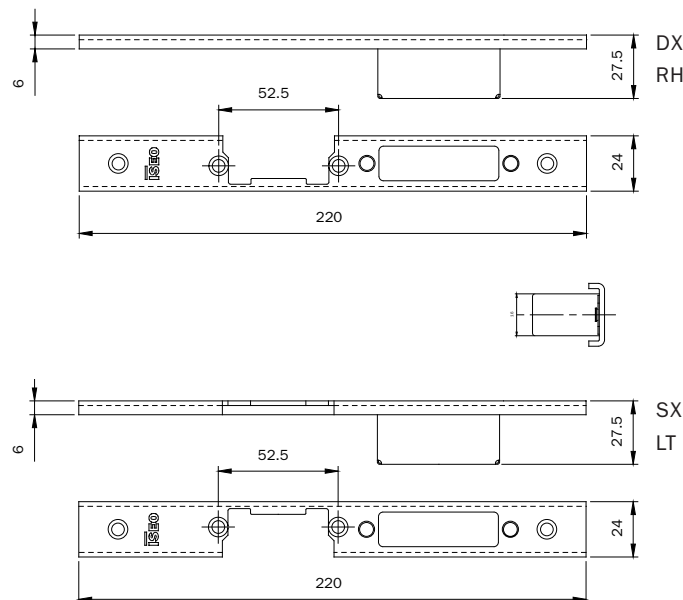

**Adatto  
per maniglioni  
antipanico  
Iseo serie:  
941\* 942\* 944\***

**Suitable  
for Iseo panic exit  
devices  
type:  
941\* 942\* 944\***

**Non adatto  
per uso su porte  
tagliafuoco.**

**Do not use  
on fire doors.**



<b>Codice Code</b>	<b>Voltaggio Voltage</b>	<b>Finitura Finishing</b>	<b>Imballo Packing</b>
<b>5680000</b>	<b>12 V. AC/DC°</b>	<b>Nero Black</b>	<b>1</b>
<b>5680003</b>	<b>12 V. AC/DC°</b>	<b>Grigio Grey</b>	<b>1</b>
<b>5680004</b>	<b>12 V. AC/DC°</b>	<b>Bianco White</b>	<b>1</b>
<b>5680020</b>	<b>24 V. AC</b>	<b>Nero Black</b>	<b>1</b>
<b>5680023</b>	<b>24 V. AC</b>	<b>Grigio Grey</b>	<b>1</b>
<b>5680024</b>	<b>24 V. AC</b>	<b>Bianco White</b>	<b>1</b>

CE



° Tempo massimo  
di alimentazione:  
10 secondi  
Maximum power  
supply time:  
10 seconds

## Incontro elettrico per maniglioni antipánico serie Idea e Push-Bar

Incontro elettrico per maniglioni antipánico serie Idea e Push-Bar  
Apertura con sganciamento permanente dopo l'impulso elettrico. Adatto per profili coplanari e con sormonto fino a 24 mm.

## Electric door openers for panic exit devices type Idea and Push-Bar

Electric door openers for panic exit devices type Idea and Push-Bar  
Opening by automatic release, suitable on coplanar profiles and on those with an overlap up to 24 mm.

**ISEO**

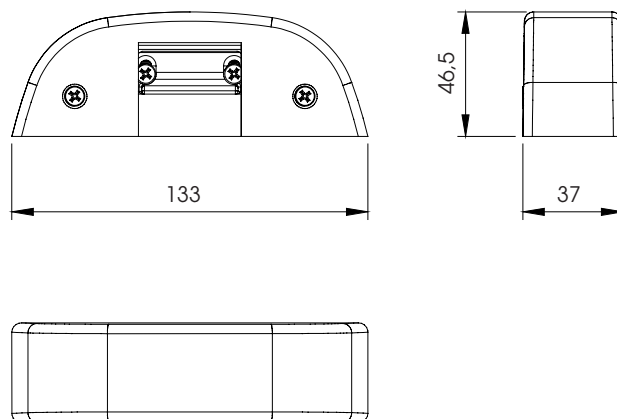



**Iseo** Serrature spa  
Via San Girolamo 13  
I-25055 Pisogne (BS)  
Telefono (39) 0364 88 21  
Fax (39) 0364 88 22 63  
[www.iseoserrature.it](http://www.iseoserrature.it)